

Cook Top + Oven – Combination Series

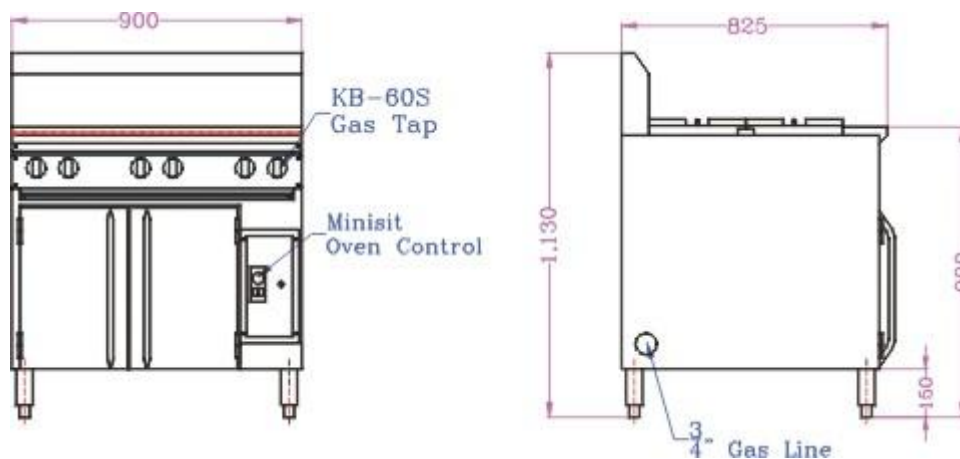

Combination oven series designed with the professional in mind. Each unit is available in various configurations, ranging from 4-10 boiling burners all interchangeable with Char Grill or Burger plate option. The unit is also available with 2 ovens.

- Stainless steel exterior
- Heavy duty enamelled cast iron trivets
- Pilot lights to all open burners
- Sturdy steel tube frame
- Enamelled oven interior
- Fully insulated panels
- Removable stainless steel oven doors
- Interchangeable stainless steel leg and castor
- Chrome plated 4 level oven rack with 2 oven rack
- Oven uses an aromatic burner system which supplies consistent heat throughout the oven
- Stove burners have extra heavy duty cast iron mushroom cap with vertical slots for high performance
- BBQ grill uses a “J” shaped drain design - creating less smoke, and keeping burners clean at all times
- Hot plate uses a “H” shaped burner which provide evenness of cooking and fast heat up time.



Model Numbers	Number of Burners	Dimensions: (W x D x H)	Gas Capacity (MJ):	Optional
AL600CTO	4	600 x 825 x 900	125	Char Grill or Burger Plate*
AL900CTO – <i>Picture Shown</i>	6	900 x 825 x 900	185	Char Grill or Burger Plate*
AL1200CTO	8	1200 x 825 x 900	250	Char Grill or Burger Plate*
AL1500CTO	10	1500 x 825 x 900	310	Char Grill or Burger Plate*

